

Secondary Round Vinyl Railing Installation Instructions (1.5" & 2")



www.fairwayvinyl.com

I It is the responsibility of the installer to meet or exceed all code and safety requirements, and to obtain all required building permits. These instructions are only a guide and may not address every circumstance. The deck and railing installer should determine and implement appropriate installation techniques for each situation.

FAIRWAY Vinyl Systems shall not be held liable for improper or unsafe installations.

Sketch a layout of the new secondary railing in relationship to the existing railing noting the various pieces you will need and where you will need them. Check to see if you have all the pieces that you will need. Determine the height of the railing (35" to 38" for commercial applications) and check how the height works coming down or up the steps. Establish a place to begin. Usually, that will be an inside corner.

Bit Recommendations:

Into Post (A, **Step 1**) Screw #14 x 1 1/2" – Pilot Bit 3/16" – Phillips Bit P3
 Into Hand Rail (A, **Step 3**) Screw #14 x 1-1/4" – Pilot Bit 3/16" – Phillips Bit P3
 Into Connector (B, **Step 3**) Screw #8 x 1" – Pilot Bit 5/32" – SQ2 Bit

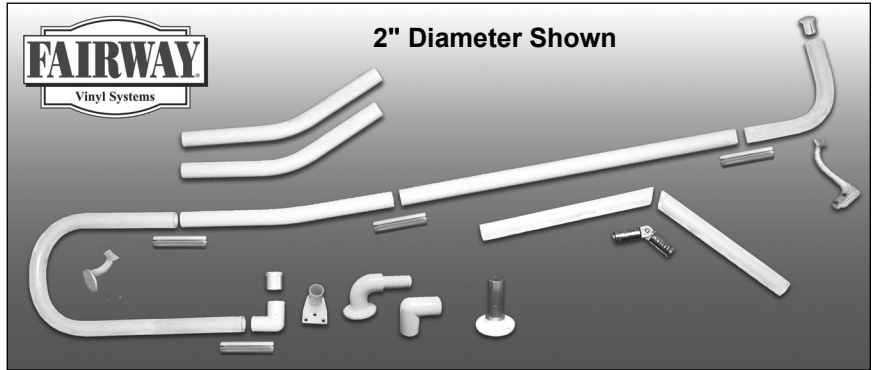
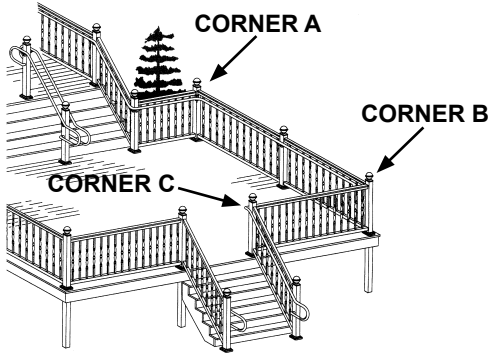

CORNER A

Measure from the floor to the top of the bracket. Height should be railing height less 2". Mark posts and install brackets.

Align elbow so that there is equal distance from one side of the elbow to the existing railing, as with the other side.

Make sure that the elbow is flat, drill pilot holes and secure with screws.

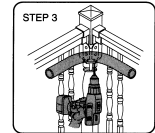
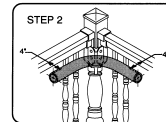
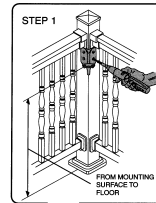

CORNER B

Install elbow using the same instructions as in Corner A.

Hand Rail: Measure distance between Corners A and B. Add required pieces to corners using connector.

Pump pliers or vise grips can be used to fit connector into the hand rail as well as tapping, as required, with a heavy rubber mallet. Final length may need to be cut for exact fit. Remove Corner B and fit together with handrail. Return Corner B to bracket and secure with screws.

NOTE: Wherever two ends of secondary handrail are joined, either to each other or to elbows, tighten the joint by drilling and securing with screws. Don't forget to use washer and plastic caps with screws.

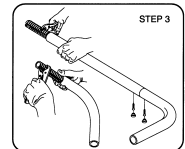
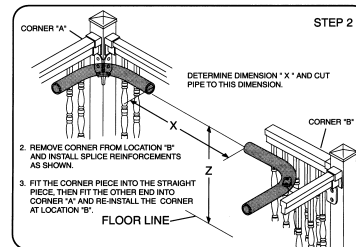
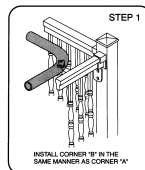

CORNER C

Making outside corners is best accomplished using a modified 90° post return. Cut a piece of aluminum that has been removed from scrap handrail to a length of 2". This piece is then inserted into the post return enabling the use of a connector to make the corner.

Determine the length to cut the handrail which is joined to the modified post return, by inserting the next piece of railing or elbow into the corner and laying it over the adjacent piece on the other side of the corner. This will establish a mark to cut the railing.

Using a connector, join the corner with the railing cut in previous step and secure to the bracket as shown.

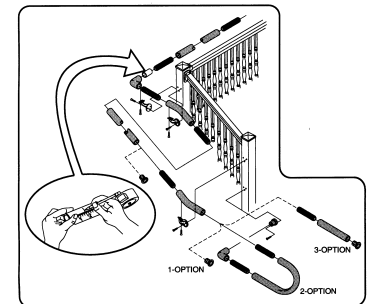

"P" LOOP INSTALLATION

- With corner now in place, determine the height of the in-line brackets on a step railing installation by holding a piece of railing in line with the elbow and parallel to the primary railing. Typically, the secondary railing will be below the level of the primary railing.
- Install in-line brackets with screws, putting brackets on every post. Continue until ground level post is reached. At this point railing will be terminated in one of a number of ways: either by end capping a straight rail, end capping an elbow, or by using the "P" loop return to meet certain municipal requirements. (See 3 options above.)

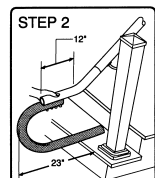

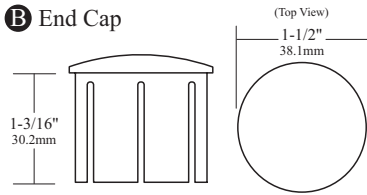
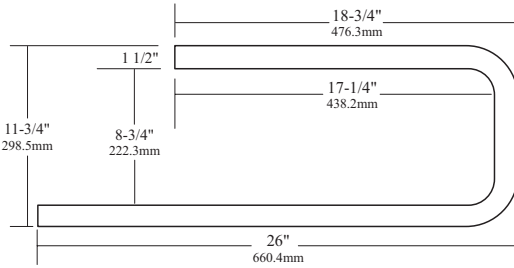
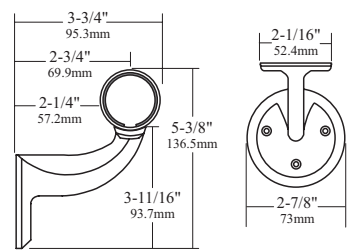
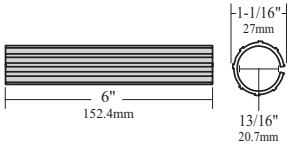
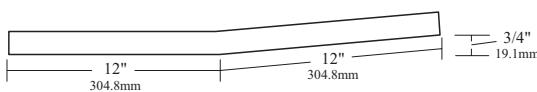
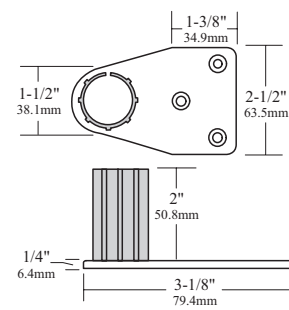
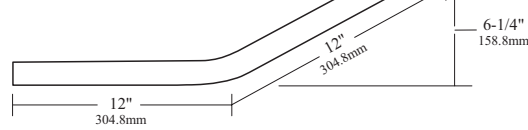
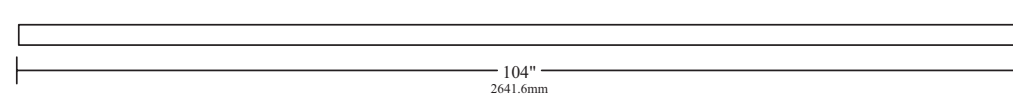
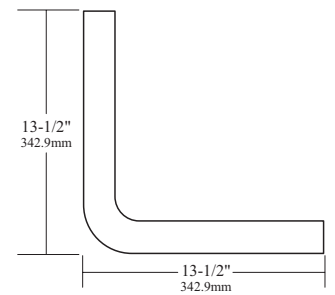
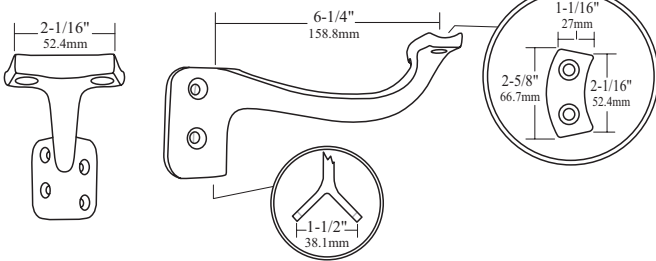
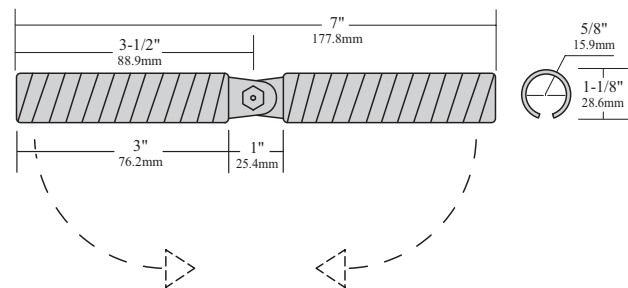
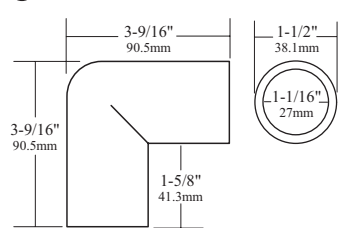
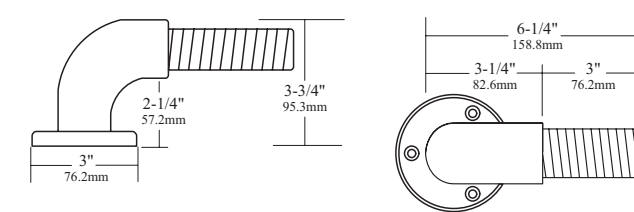
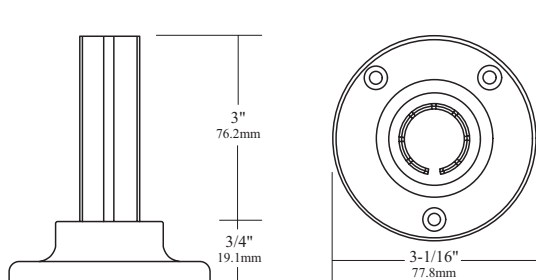
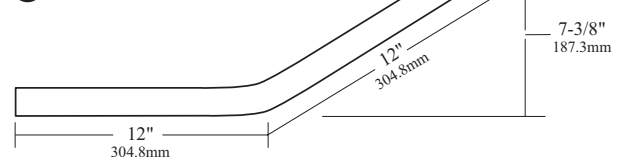
B End Cap**C P-Loop Return****D 3\"/>****E Aluminum Connector****F 5° Radius****G Aluminum Gate Return****I 32° Radius****J 1.5\"/>****K 90° Radius****L 6\"/>****M 0° - 90° Universal Elbow****N 90° Outside Elbow****O 90° Aluminum Quick Return Bracket****P 1.5\"/>****Q 38° Radius**

Dimensions and tolerances contained on drawings and figures are for reference only and may not encompass total allowable and approved dimensional variations.

DOCUMENT TITLE: **1.5\"/>**

This drawing is the property of Fairway Vinyl Systems. Any hard copy of this drawing may not be current. This document and or images contained within may not be reproduced in publication format without express written consent of Fairway Vinyl Systems. Drawings may not be to scale.

FAIRWAY VINYL SYSTEMS			
UOM inch/mm	REF# 1.5\"/>	DATE EVS	REV 1
SCALE	SHEET# 1 of 1	DRAWN BY	DATE 12-15-08