

Masters/Legends Vinyl Balustrade

LEVEL Installation Instructions



www.fairwayvinyl.com

! It is the responsibility of the installer to meet or exceed all code and safety requirements, and to obtain all required building permits. These instructions are only a guide and may not address every circumstance. The deck and railing installer should determine and implement appropriate installation techniques for each situation.

FAIRWAY Vinyl Systems shall not be held liable for improper or unsafe installations.

Step 1 Safety Precautions

Check all local building codes for design load requirements. Fairway Masters Vinyl Balustrade is compliant with Section 4.2 Guardrail System Structural testing of IBCO AC174 (April 2002) Acceptance Criteria for Deck Board Span Ratings and Guardrail Systems (*Guard and Handrail*). Always use safety equipment.

Step 1 Mounting Surface Preparation

Make sure all mounting surfaces are plumb. If using a Round Column, make sure to use a Round Column Adapter. When using a Square or Recessed Panel Newel Post Sleeve, pad wood post out to fit the inside of post sleeve or you may use our Stainless Steel Structural Post (see Figure 2). Slide sleeve over post and slide base trim ring in place.

Step 2 Cut Top And Bottom Rails

With post plumb, measure the distance between posts where rail brackets will mount. Lay rails on a flat non-abrasive surface. Using the measurement between posts as a reference, measure the bottom rail, allowing equal and maximum distance between end of rail and baluster. Make sure you have a minimum of 1" from end of rail to baluster. With layout complete, mark where rails will be cut. You may mark both top and bottom rails at one time. You may cut both aluminum and vinyl at the same time using a saw with a fine tipped carbide saw blade (see manufacturer specs for saw blade).

Step 3 Assemble Rail And Mounting Brackets

With rail cut to length, insert balusters in bottom rail. Widest part of turned baluster goes into bottom rail (see Figure 3). With all balusters in bottom rail, hold top rail at an angle and start to insert balusters into top rail. Using two straps or cord wrap around rail section and tie off to hold rail together when moving in place. Slide brackets on ends of rail section (two bottom and two top brackets). If mounting bracket covers baluster cut out, you may cut out up to 1" of the mounting bracket flange, using a coping saw or saber saw, to allow baluster to seat into rail. Using scrap lumber, cut two 2" blocks and lay 8" away from post so bottom rail will rest on blocks to allow proper space between deck and rail (see Figure 4).

Step 4 Mount Railing To Post

With rail assembled, mounting brackets placed on rail ends, set rail in between post on top of 2" blocks. Next, center mounting brackets on newel post. Drill a 5/32" hole through mounting bracket screw holes (four per bracket) into post and install four (4) mounting bracket screws on all (4) brackets. With all brackets screwed in place, you will need to install a screw, washer and white cap through each bracket into the rails. Drill a hole in center of the mounting bracket (close to the post if possible) one screw per bracket, bottom of top bracket and top of bottom bracket (see Figure 5).

Step 5 Install Post Caps

With railing screwed in place, you are ready to install post caps. If you need to trim the tops of newel posts you may do this now. To install post caps, apply PVC cement or Silicone Caulk to the inside lip of cap and seat in place.

Step 6 Cleanup

You may clean up your vinyl railing with a mild household cleaner. For any stubborn stains, use #0000 steel wool and mild household cleaner.

MASTERS/LEGENDS VINYL BALUSTRADE

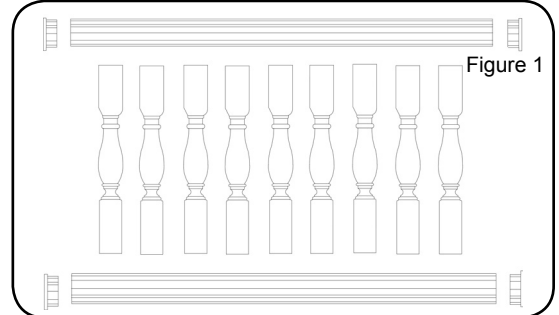

Figure 1

FITTING WOOD POSTS WITH MASTERS VINYL BALUSTRADE

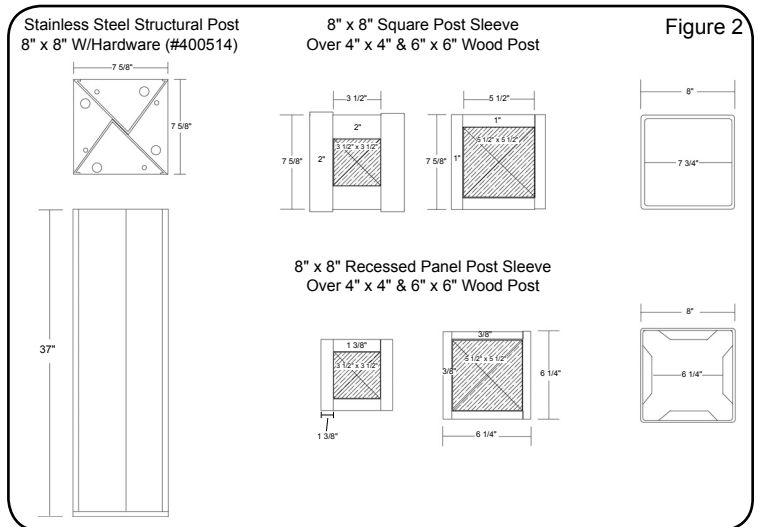

Figure 2

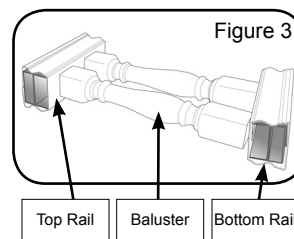

Figure 3

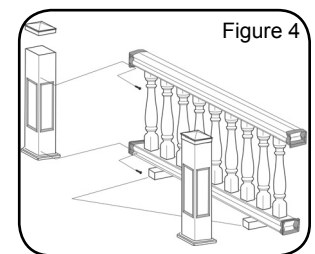

Figure 4

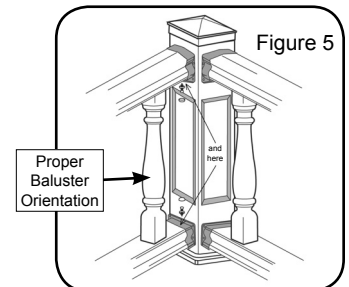

Figure 5

Masters/Legends Vinyl Balustrade

STAIR Installation Instructions



www.fairwayvinyl.com

! It is the responsibility of the installer to meet or exceed all code and safety requirements, and to obtain all required building permits. These instructions are only a guide and may not address every circumstance. The deck and railing installer should determine and implement appropriate installation techniques for each situation.

FAIRWAY Vinyl Systems shall not be held liable for improper or unsafe installations.

Step 1 Safety Precautions

Check all local building codes for design load requirements. Fairway Masters Vinyl Balustrade is compliant with Section 4.2 Guardrail System Structural testing of IBCO AC174 (April 2002) Acceptance Criteria for Deck Board Span Ratings and Guardrail Systems (*Guard and Handrail*). Always use safety equipment.

Step 2 Mounting Surface Preparation

Make sure all mounting surfaces are plumb. You may use a 54" vinyl sleeve in square or raised panel (*Legends also has a Turned Newel*). Wood post will need to be built out to match the inside measurements of post sleeve or you may use our Stainless Steel Structural Post. (*Structural Post required with Legends Turned Newel Post*). **NOTE:** Base Trim Rings may need to be modified for stair rail.

Step 3 Lay Out Bottom Rail

With all mounting surfaces prepared, remove bottom rail from carton (*Legends Top & Bottom Rails are the same profile*) and remove aluminum insert. Rest bottom rail on deck and bottom stair nosing. (*See Figure 1.*) Make sure distance from baluster to newel is equal on both ends. Make a vertical mark along bottom rail.

Step 4 Cut Bottom Rail and Aluminum Inserts

With bottom rail marked, deduct 1/2" off both ends of rail to allow for mounting brackets (*see Figure 2*). You may cut with a power mitre box or power saw. Next, cut the aluminum insert 3-1/2" shorter than vinyl rail length. Use a power mitre box or power saw (*see manufacturer specs for saw blade*).

Step 5 Install Mounting Brackets

With rail and aluminum insert cut to length, slide Sleeve Over over both ends of bottom rail. Insert mounting bracket in end of bottom rail, hold flush with rail end and adjust so all screw holes are accessible. Slide Sleeve Over forward so it is flush with mounting bracket flange. At middle mounting bracket screw hole, measure over 3/4" on Sleeve Over and drill a 1/8" hole through Sleeve Over, rail and mounting bracket. Slide the clear plastic washer over the #8 x 1" SS screw head (*recessed in washer*) and screw into the 1/8" hole through Sleeve Over, rail and bracket (*one screw per side*). Snap white plastic cover over clear washer. Set rail in place between mounting surfaces, center mounting bracket and adjust height. Mark screw holes in mounting bracket and remove from opening. Next, pre-drill six (*per bracket*) 5/32" holes in center of mark. Set bottom rail in place and install six #12 x 2" SS white head screws through bottom bracket into 5/32" hole.

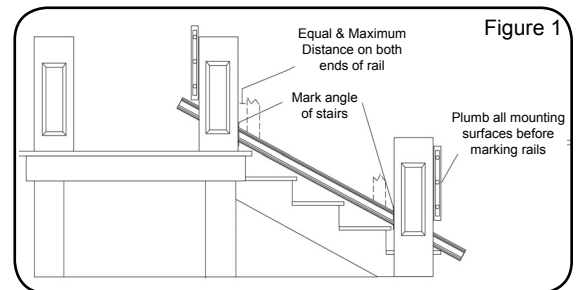

Step 6 Lay Out Top Rail

With bottom rail in place, insert one baluster in bottom rail closest to mounting surface. Pulling over to one side, insert baluster in matching hole in top rail (*see Figure 3*). **NOTE:** At this time if you wish to adjust the height of your railing, you may do so by cutting even amount of top and bottom baluster (*maximum adjustment 5"*). (**TIP:** *On steeper pitch stairs, it may be necessary to cut the bottom & top of balusters at same pitch of steps to allow for deeper baluster insertion*). Make sure you have equal distance from mounting surface to baluster at top and bottom rail. Make a vertical mark where rail and mounting surface meets (*see Step 3*).

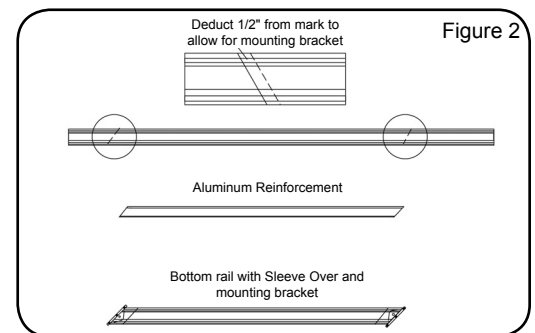

Step 7 Cut Top Rail and Insert Mounting Brackets

Procedure for cutting top rail and installing mounting brackets will be the same as bottom rail. Repeat **Steps 3, 4, and 5**.

Step 8 Set Top Rail in Place

With top rail cut to length and mounting brackets in place, insert all balusters in bottom rail with wide part of turned baluster toward the bottom (*see Figure 4*). Slide top rail in place, starting at bottom baluster and working your way up to the top baluster. With all balusters in place, screw top mounting brackets in place the same way as bottom mounting brackets (*see Step 5*).

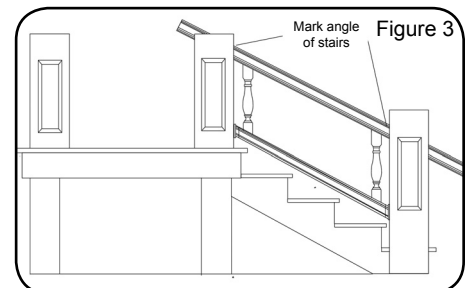

Step 9 Install Post Caps

With railing screwed in place, you are ready to install post caps. If you need to trim the tops of newel posts you may do this now. To install post caps, apply PVC cement or Silicone Caulk to the inside lip of cap and seat in place.

Step 10 Cleanup

You may clean up your vinyl railing with a mild household cleaner. For any stubborn stains, use #0000 steel wool and mild household cleaner.

NOTE: Depending on the pitch of the steps, it may become necessary to notch out bottom and top rail Sleeve Over if they cover baluster pocket, and top and bottom of baluster if it is in contact with internal stair bracket. It may also be necessary to cut the top and bottom of baluster to match the pitch of the steps to allow for deeper insertion in top and bottom rail.

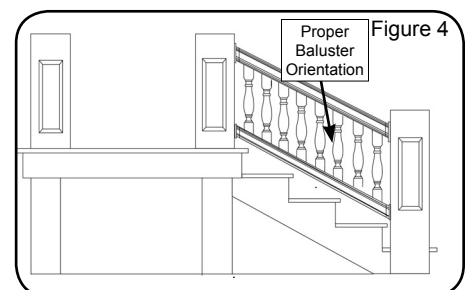

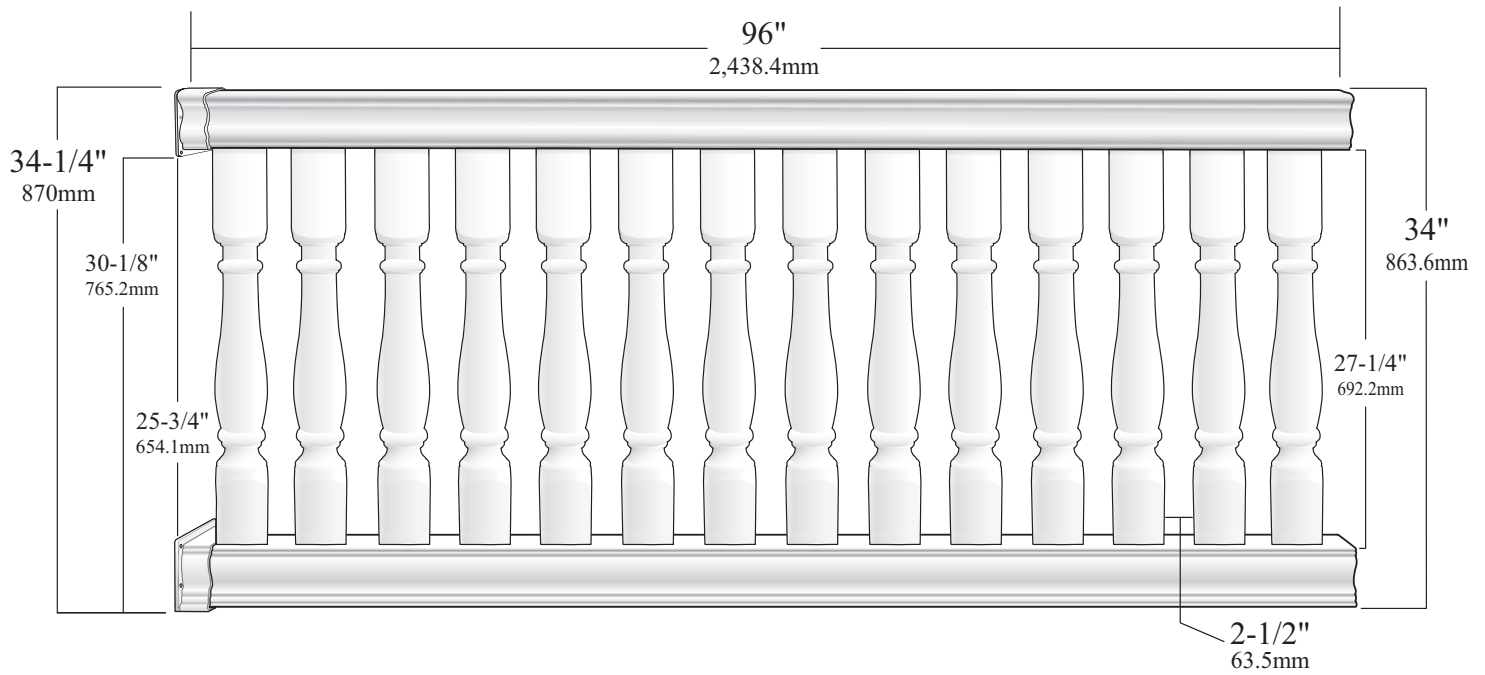

Masters Top Rail Level Bracket

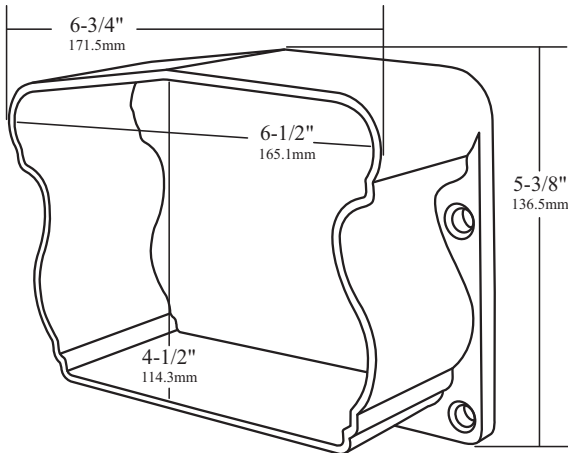

29" Masters Turned Balusters

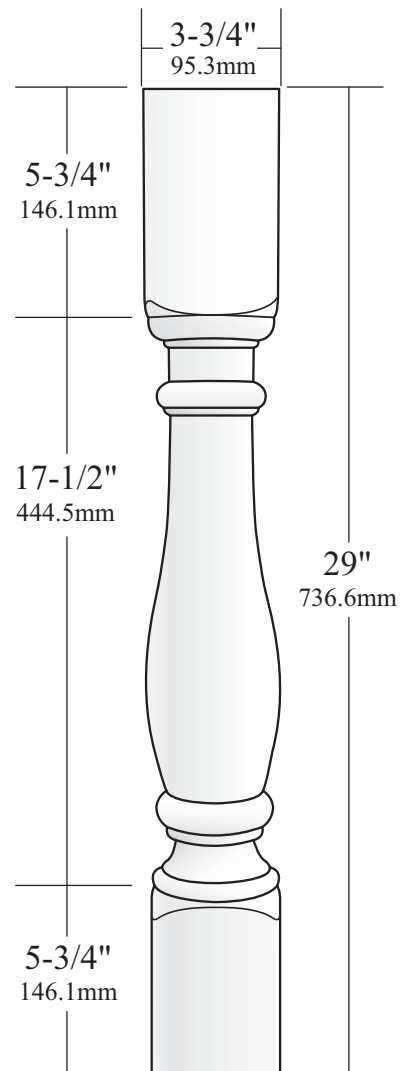

Masters Bottom Rail Level Bracket

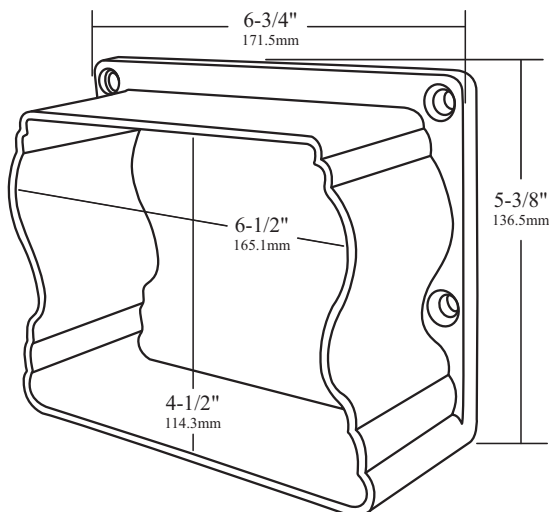

DOCUMENT TITLE:		8' Masters Level Rail System - 36" Height			
This drawing is the property of Fairway Vinyl Systems. Any hard copy of this drawing may not be current. This document and/or images contained within may not be reproduced in publication format without express written consent of Fairway Vinyl Systems. Drawings may not be to scale.		FAIRWAY VINYL SYSTEMS			
P.O. Box 37 Mount Joy, Pa 17552		UCM REF#	VSMA 400444 P1	REV	1
SCALE	SHEETS	1 of 1	DRAWN BY	DATE	7-17-08
			FVS		

Dimensions and tolerances contained on drawings and figures are for reference only and may not encompass total allowable and approved dimensional variations.

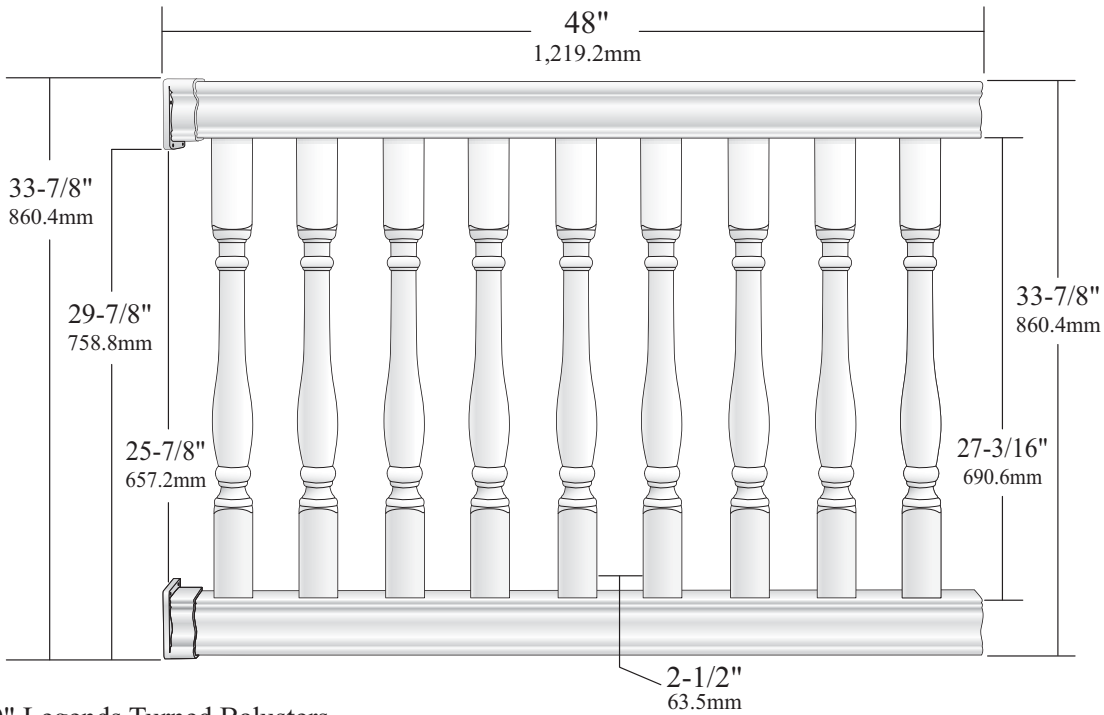

30" Legends Turned Balusters

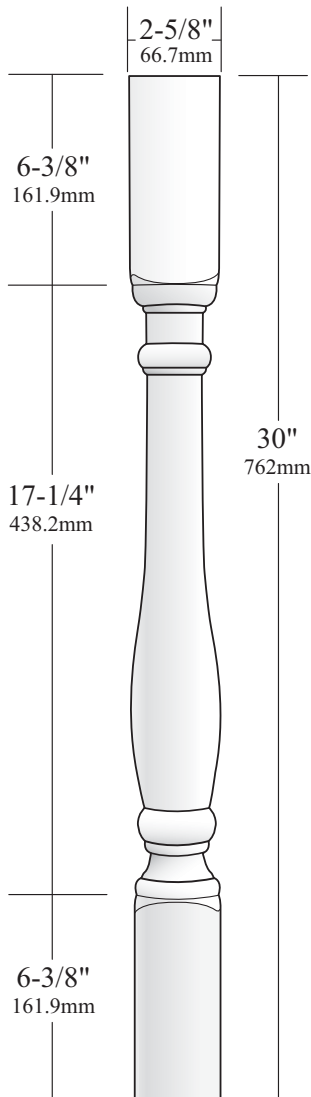

Legends Level Rail Brackets
(Same Bracket for Top and Bottom Rails)

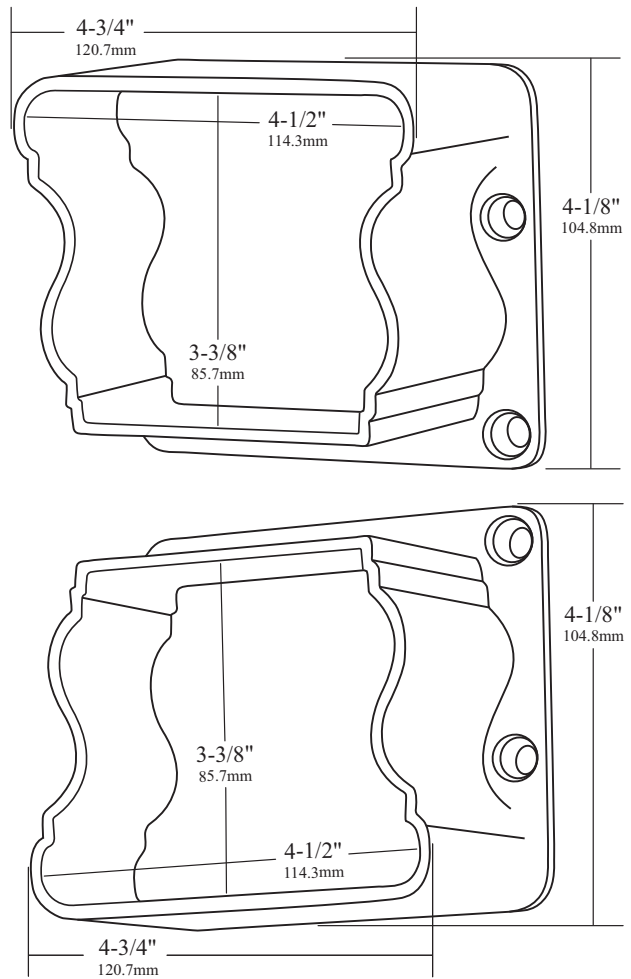

DOCUMENT TITLE:				4' Legends Level Rail System - 36" Height			
This drawing is the property of Fairway Vinyl Systems. Any hard copy of this drawing may not be current. This document and or images contained within may not be reproduced in publication format without express written consent of Fairway Vinyl Systems. Drawings may not be to scale.				FAIRWAY VINYL SYSTEMS			
P.O. Box 37 Mount Joy, Pa 17552				REF# VSLE 400700 P1			
SCALE	SHEETS	1 of 1	DRAWN BY	DATE	REV	1	7-18-08

Dimensions and tolerances contained on drawings and figures are for reference only and may not encompass total allowable and approved dimensional variations.

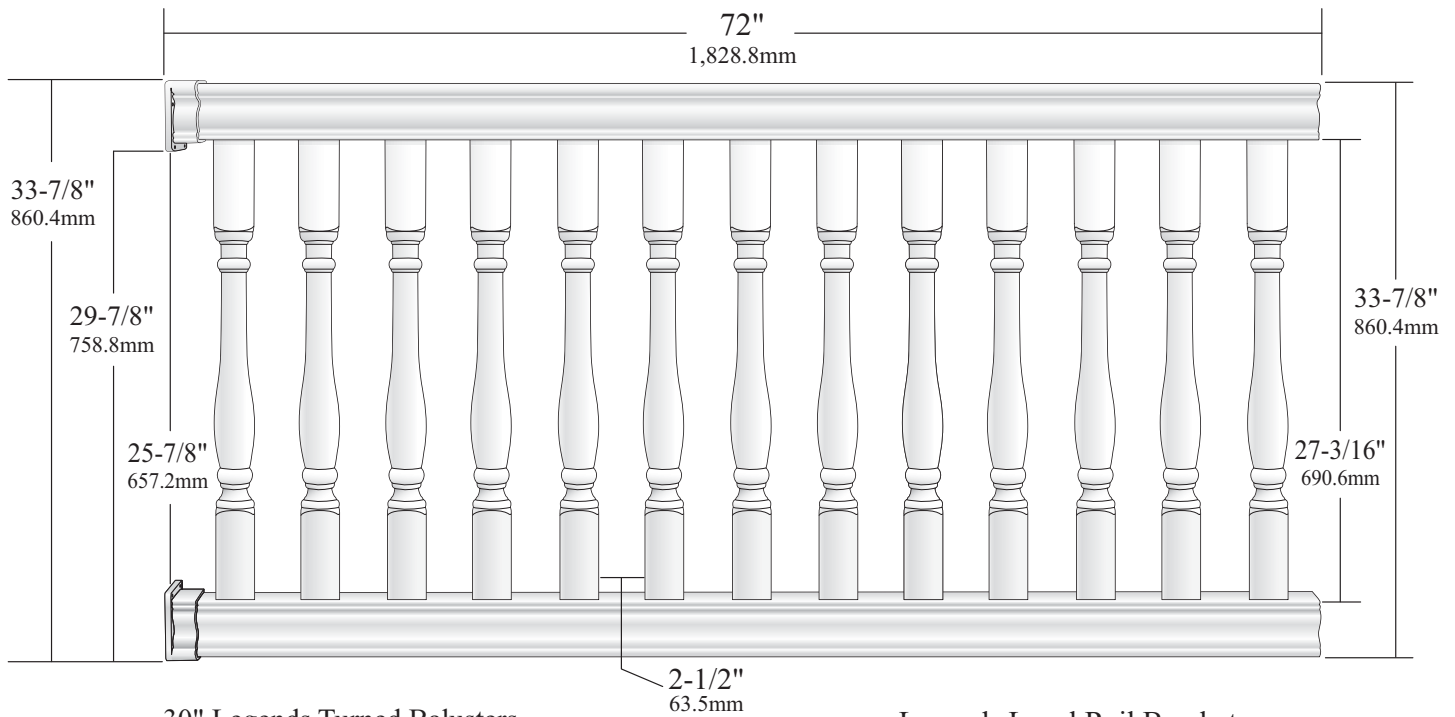

30" Legends Turned Balusters

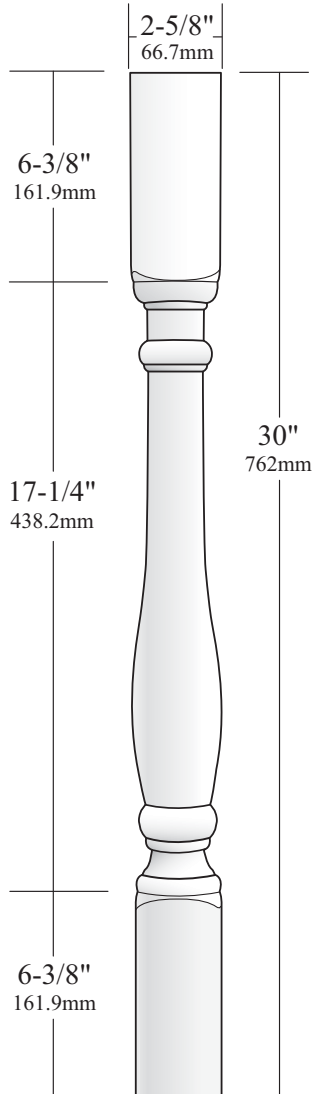

Legends Level Rail Brackets
(Same Bracket for Top and Bottom Rails)

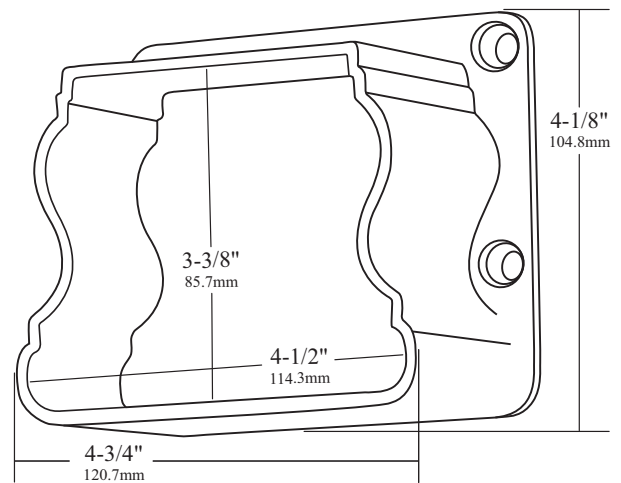
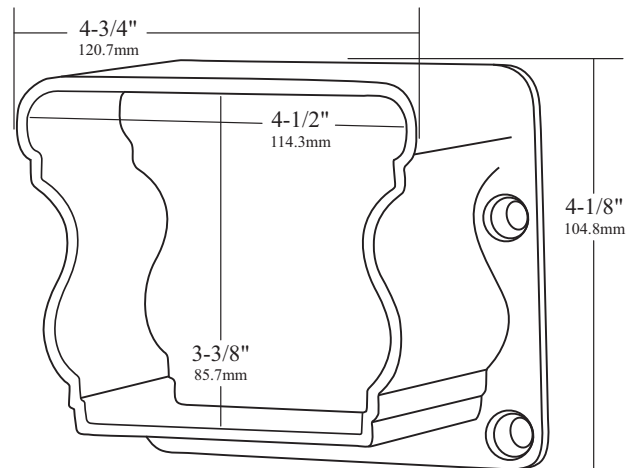

DOCUMENT TITLE:		6' Legends Level Rail System - 36" Height			
This drawing is the property of Fairway Vinyl Systems. Any hard copy of this drawing may not be current. This document and/or images contained within may not be reproduced in publication format without express written consent of Fairway Vinyl Systems. Drawings may not be to scale.		FAIRWAY VINYL SYSTEMS			
P.O. Box 37 Mount Joy, Pa 17552		UOM	REF#	VSL#	REV
		inches		400702 P1	1
SCALE:	SHEET#	DRAWN BY:	DATE:		
1 of 1		FVS	7-18-08		

Dimensions and tolerances contained on drawings and figures are for reference only and may not encompass total allowable and approved dimensional variations.

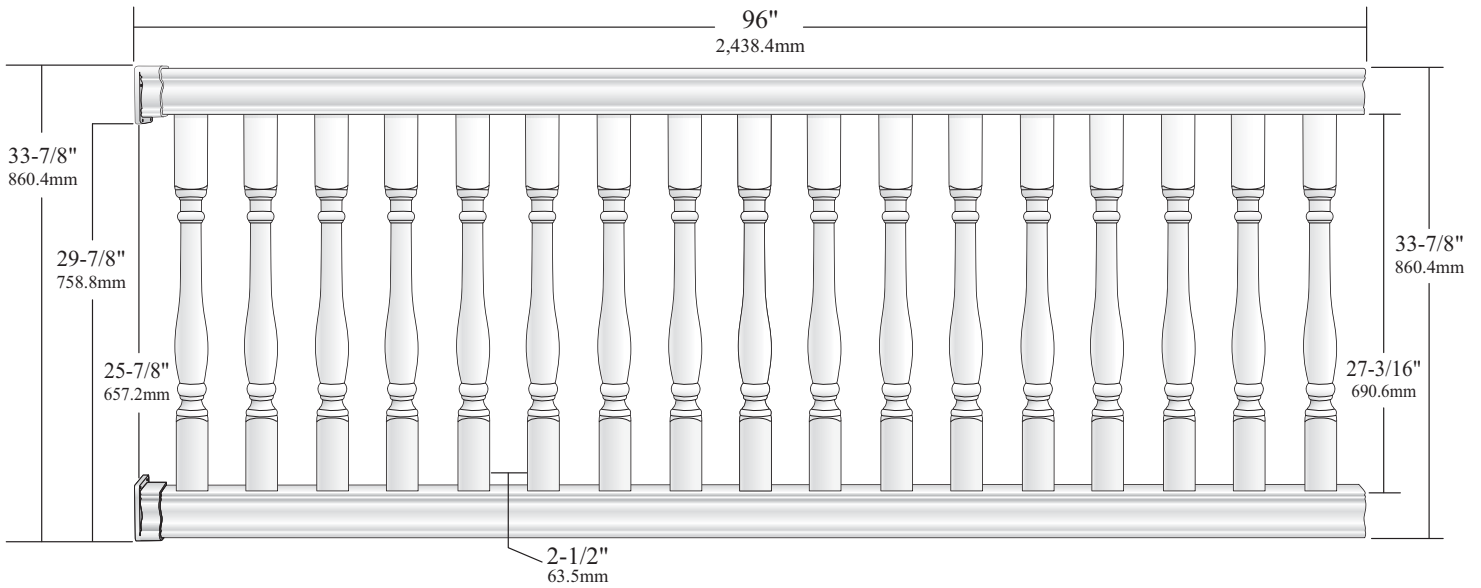

30" Legends Turned Balusters

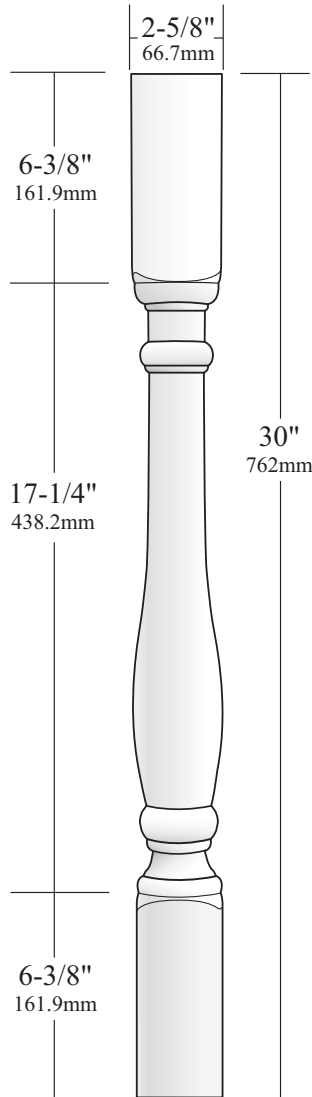

Legends Level Rail Brackets
(Same Bracket for Top and Bottom Rails)

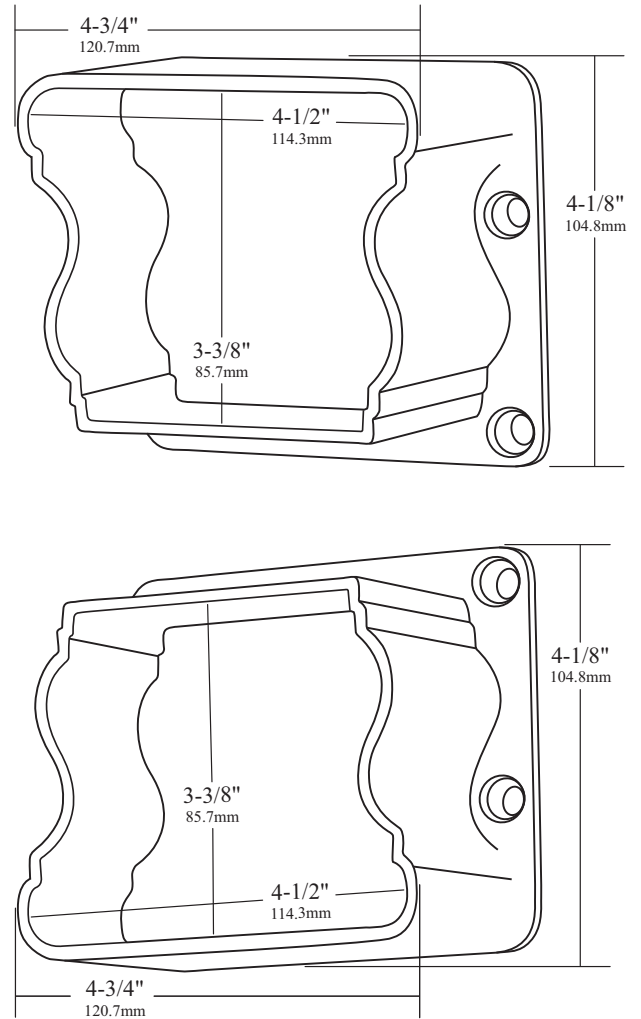

DOCUMENT TITLE:		8' Legends Level Rail System - 36" Height			
This drawing is the property of Fairway Vinyl Systems. Any hard copy of this drawing may not be current. This document and or images contained within may not be reproduced in publication format without express written consent of Fairway Vinyl Systems. Drawings may not be to scale.		FAIRWAY VINYL SYSTEMS			
P.O. Box 37 Mount Joy, Pa 17552		UOM	REF#	DATE	REV
		inch/mm	VSLE 400704 P1		1
SCALE	SHEETS	DRAWN BY	DATE		
1 of 1		FVS	7-18-08		

Dimensions and tolerances contained on drawings and figures are for reference only and may not encompass total allowable and approved dimensional variations.

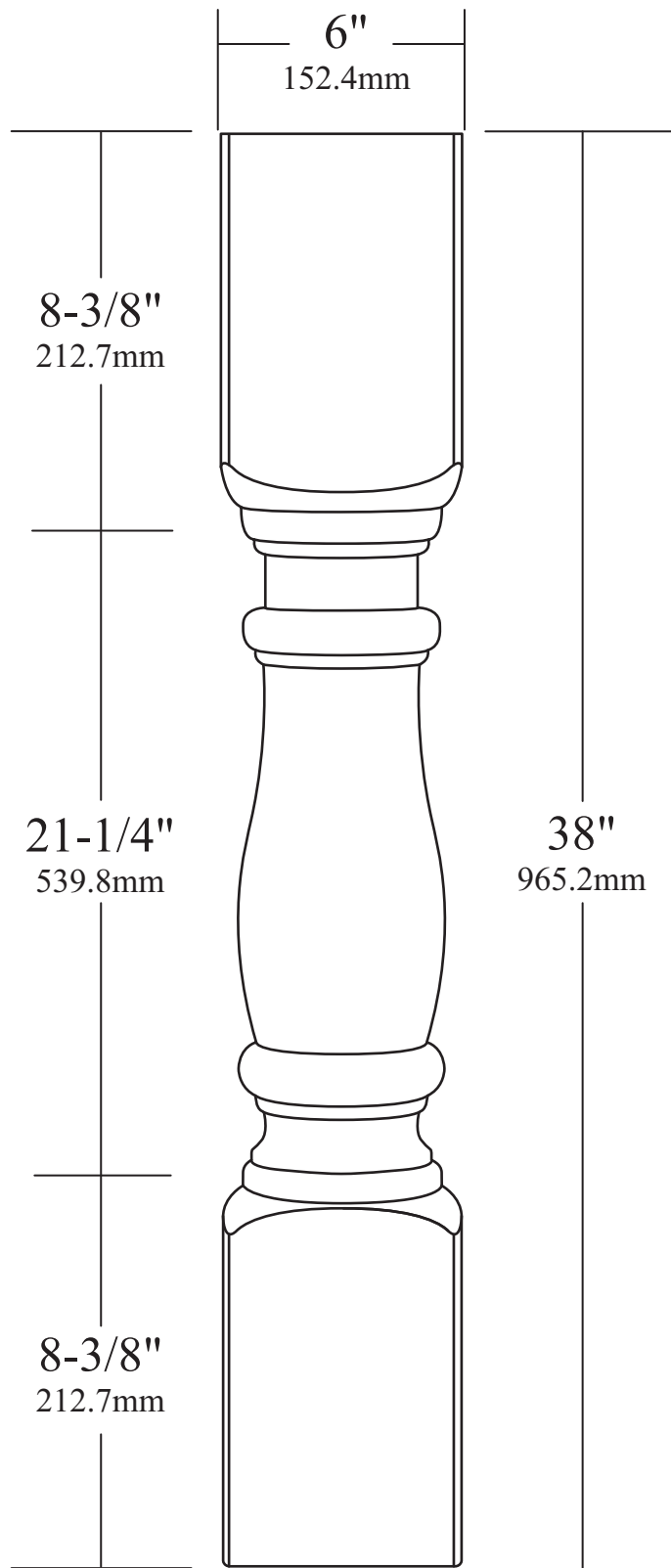

DOCUMENT TITLE:			
6" x 38" Legends Turned Newel Post			
This drawing is the property of Fairway Vinyl Systems. Any hard copy of this drawing may not be current. This document and or images contained within may not be reproduced in publication format without express written consent of Fairway Vinyl Systems. Drawings may not be to scale.			
FAIRWAY VINYL SYSTEMS			
P.O. Box 37 Mount Joy, Pa 17552			
UOM	REF#	DATE	REV
inch/mm	SVLE 400738 P1		1
SCALE	SHEETS	DRAWN BY	DATE
	1 of 1	FVS	10-7-08

Dimensions and tolerances contained on drawings and figures are for reference only and may not encompass total allowable and approved dimensional variations.

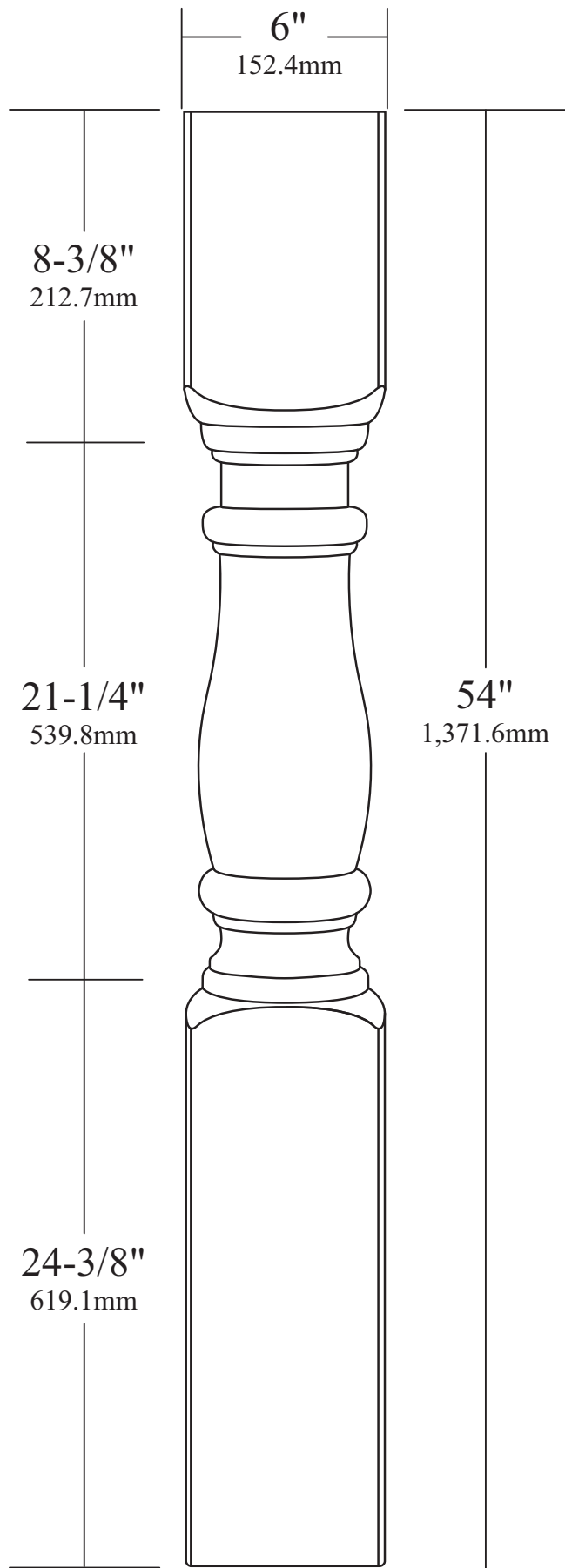

DOCUMENT TITLE:				6" x 54" Legends Turned Newel Post			
This drawing is the property of Fairway Vinyl Systems. Any hard copy of this drawing may not be current. This document and or images contained within may not be reproduced in publication format without express written consent of Fairway Vinyl Systems. Drawings may not be to scale.				FAIRWAY VINYL SYSTEMS			
P.O. Box 37 Mount Joy, Pa 17552				REF# SVLE 400740 P1		REV 1	
SCALE	SHEETS	DRAWN BY	DATE				
	1 of 1	FVS	10-7-08				

Dimensions and tolerances contained on drawings and figures are for reference only and may not encompass total allowable and approved dimensional variations.