

LANDMARKE®

NOTES:

1. This product may be constructed in any configuration up to 42" in height and 96" in width.
2. This product has been designed to comply with Section R312 of the 2006 International Residential Code and Section 1013 of the 2006 International Building Code for use in One-and-Two Family Dwellings.
3. This product has been tested to comply with the 2006 International Building Code Section 1607.7.1.1 under section 1607.7.1 Exception 1.
4. Use of spans greater than 96" is limited to one-and-two family dwellings only and requires an additional fastener through the top of the top rail into the mounting bracket (see additional detail).

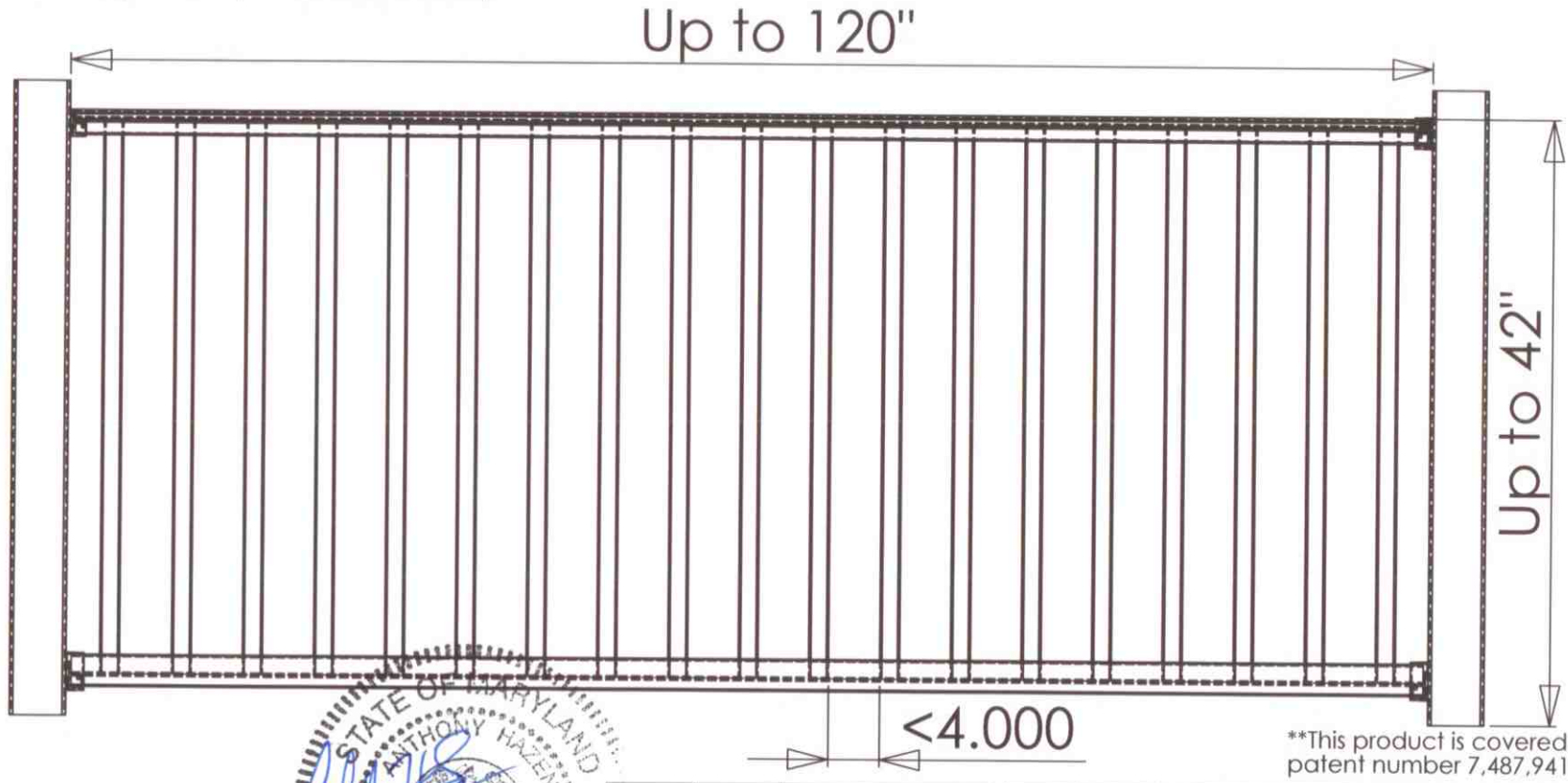

This product is covered by patent number 7,487,941B2

*Also Licensed Professional Engineer in
 Alabama 27656-E
 Florida 60320
 Georgia 22120
 Louisiana 31623
 Mississippi 16594
 North Carolina 031803
 South Carolina 24909



DIMENSIONS ARE IN INCHES: TOLERANCES: FRACTIONAL ± ANGULAR, MACH ± BEVD ± TWO PLACE DECIMAL ± THREE PLACE DECIMAL ±		NAME	DATE	LANDMARKE VINYL RAILING
DRAWN	SHH	8/17/09		
CHECKED				
ENG APPR				
MFG APPR				
Q.A.				COMMENTS:
NEXT ASSY	USED ON			SHE A DWG. NO. REV. SCALE: 1/8" WEIGHT SHEET OF
APPLICATION	DO NOT SCALE DRAWING			

>96" spans require a #10 screw driven through rail, insert and mounting bracket.
 (limited for use in one-and-two family dwellings.)

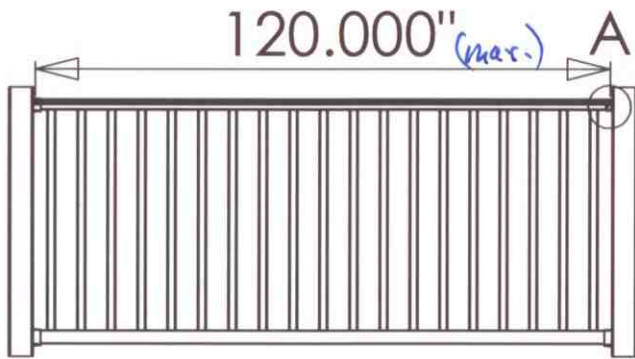
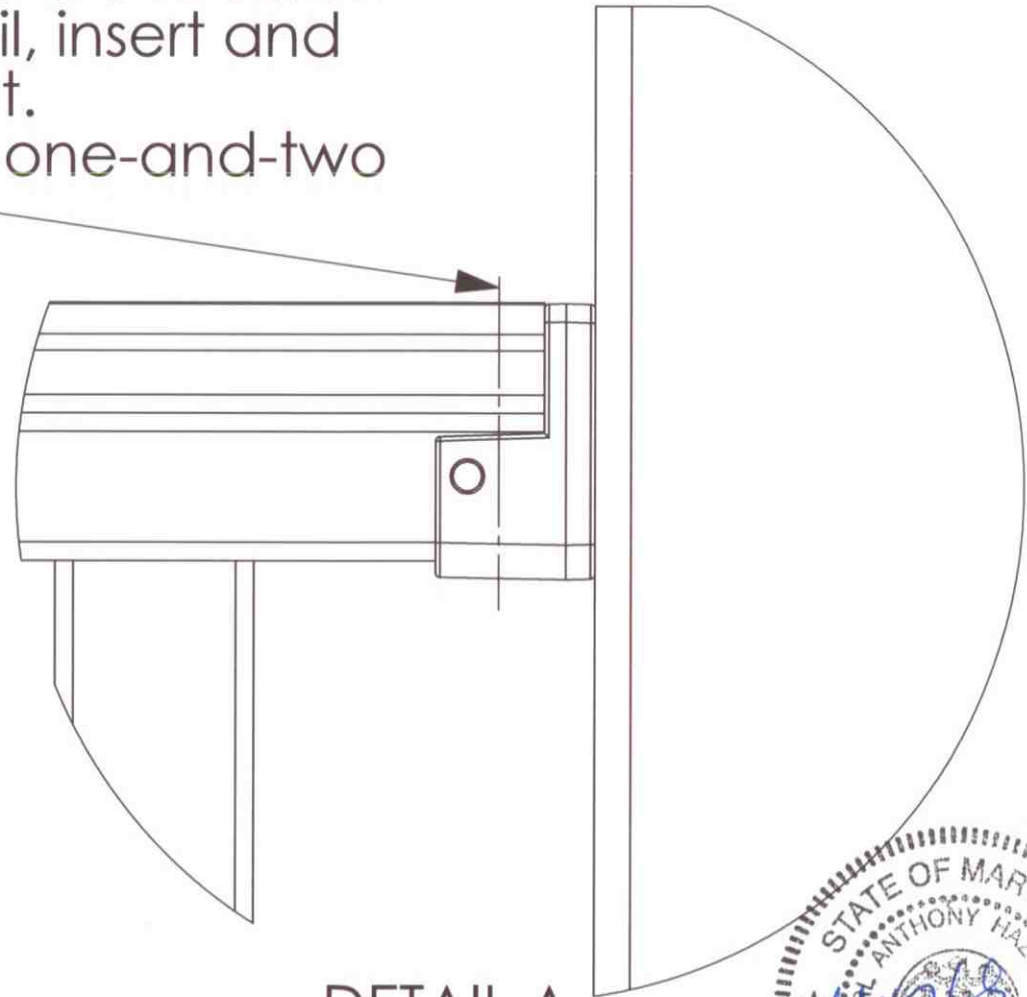

DETAIL A
 SCALE 1 : 1.25



<p>PROPRIETARY AND CONFIDENTIAL</p>	<p>DO NOT SCALE DRAWING</p>		<p>PART NUMBER</p>	<p>DESCRIPTION</p>
<p>THE INFORMATION CONTAINED IN THIS DRAWING IS THE SOLE PROPERTY OF HOMELAND VINYL PRODUCTS. ANY REPRODUCTION IN PART OR AS A WHOLE WITHOUT THE WRITTEN PERMISSION OF HOMELAND VINYL PRODUCTS IS STRICTLY PROHIBITED.</p>	<p>DIMENSIONS ARE IN INCHES TOLERANCES: FRACTIONAL ± 1/16 ANGULAR: MACH ±1° BEND ±2° TWO PLACE DECIMAL ±.06 THREE PLACE DECIMAL ±.063</p>		<p>DRAWN BY</p>	
			<p>DRAWN DATE</p>	
			<p>ENG APPR</p>	<p>FILE NAME</p>
			<p>MATERIAL</p>	<p>C:\Documents and Settings\Stan Halhorn\Desktop\Homeland Files\Homeland Files\Testing\Nexus US</p>
			<p>WEIGHT</p>	<p>REV SHEET 1 OF 1</p>